

KOFFERTRÄGER EXTREME

Case carrier | Portamaletas | Porte-bagages | Supporto per valigie

Art.-Nr: 13601-000

DIE MONTAGE DER BAUTEILE IST SOWOHL AUF DER LINKEN ALS AUCH AUF DER RECHTEN SEITE IDENTISCH.

The installation of the components is identical on both the left and right sides.
L'installation des composants est identique sur le côté gauche et le côté droit.



LEGENDE/KEY/FILE LÉGENDE

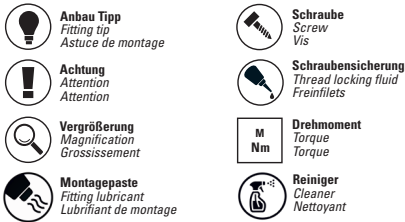

#	Bauteil component composant	DE Die Farben der Abbildungen dienen nur der Veranschaulichung. EN The colors are for illustrating purposes only. FR Les couleurs utilisées sont à titre indicatif seulement.	DIN	ISO	Menge quantity quantité
1	U-Scheibe / Washer M8		125A2	7089	2
2	Linsenflanschschraube / Lens head screw M8x20		7381A2	7381	4
3	Sechskantmutter / Hex nut M8		985A2	10511	2
4	Hülse / Sleeve 2,4mm				4
5	Hülse / Sleeve 4mm				2
6	Querstrebe / Cross brace				1
7	Rechter & linker Kofferträger / Luggage rack right & left side				2
8	Schraubensicherung / Thread locking fluid				1

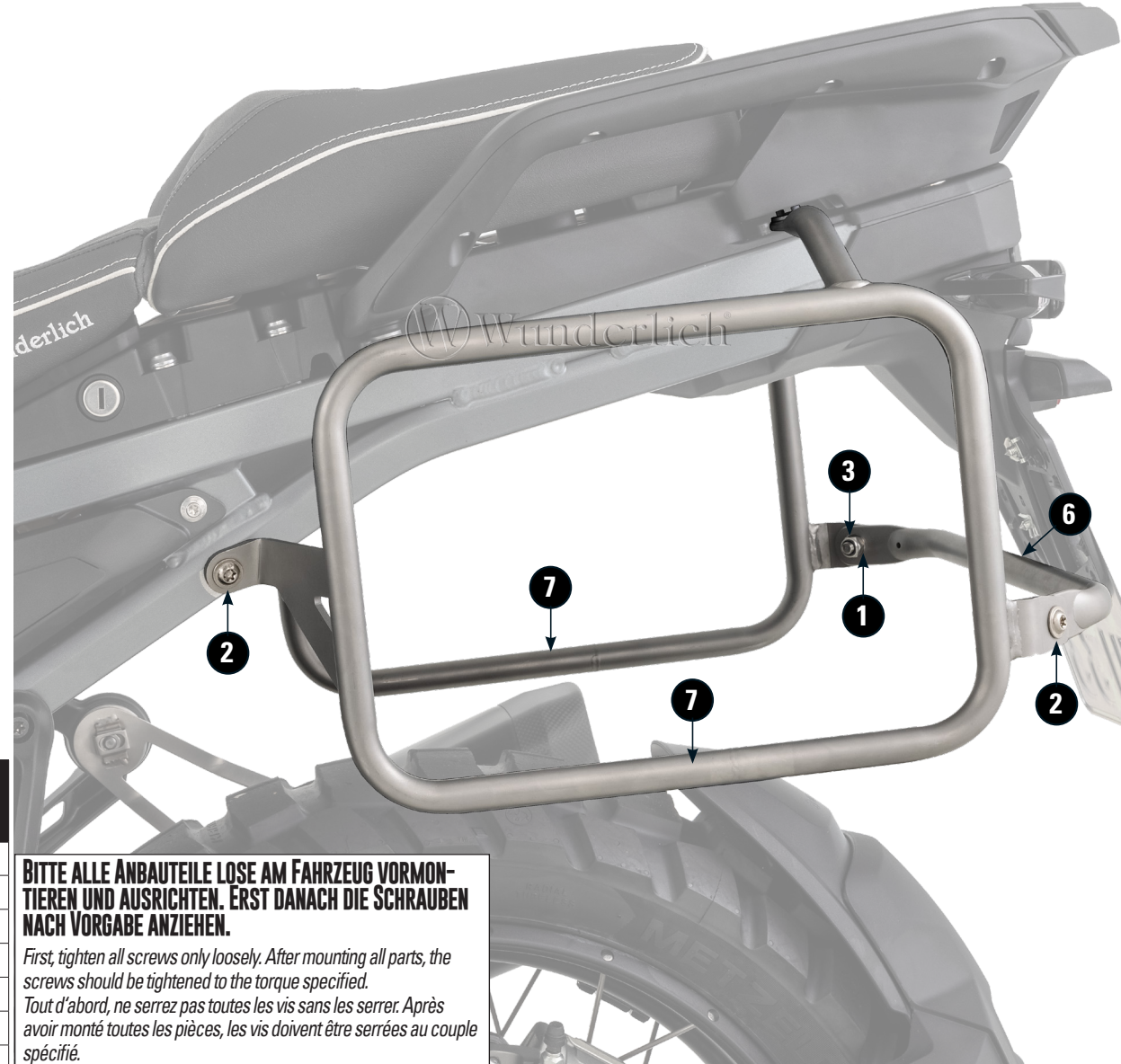

BITTE ALLE ANBAUTEILE LOSE AM FAHRZEUG VORMONTIEREN UND AUSRICHTEN. ERST DANACH DIE SCHRAUBEN NACH VORGABE ANZIEHEN.

First, tighten all screws only loosely. After mounting all parts, the screws should be tightened to the torque specified.
Tout d'abord, ne serrez pas toutes les vis sans les serrer. Après avoir monté toutes les pièces, les vis doivent être serrées au couple spécifié.

100225



1



2

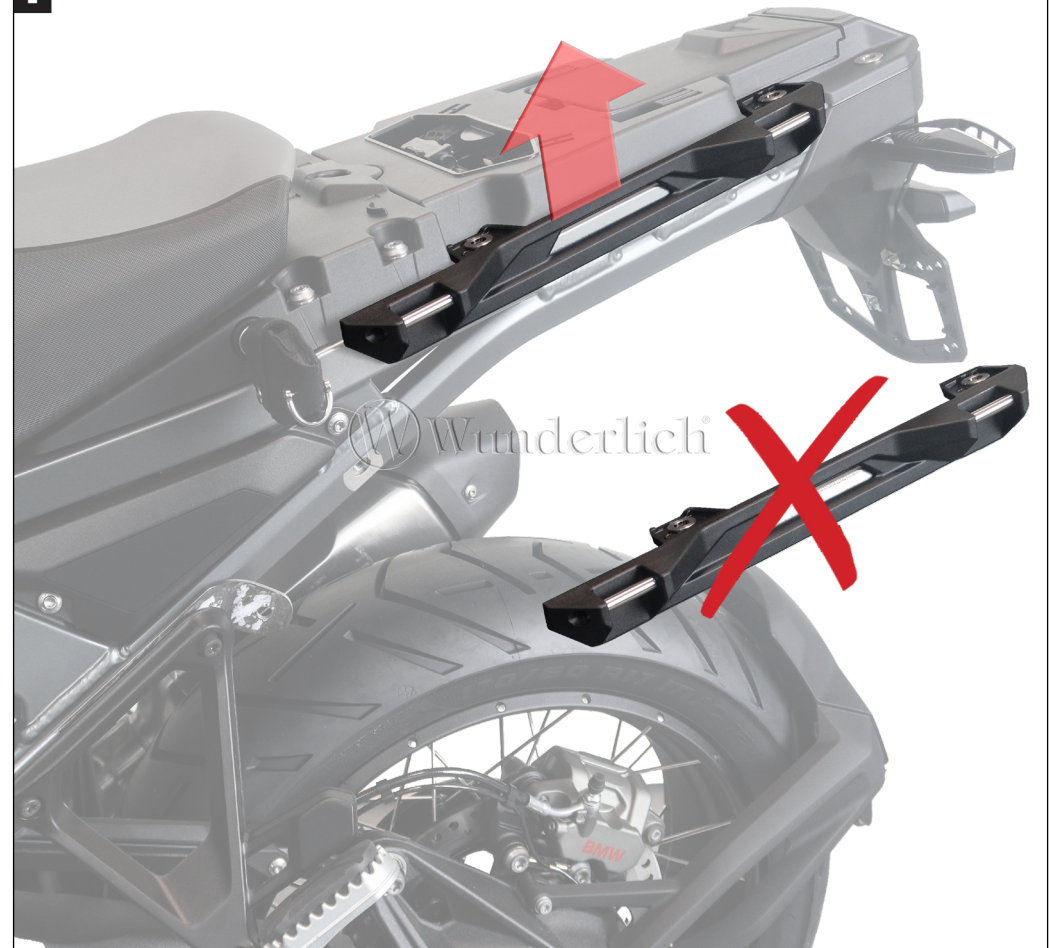

GEPÄCKBRÜCKE ODER HALTEGRIFFE DEMONTIEREN.

Removing the luggage rack or grab handles.

Démontage du porte-bagages ou des poignées de maintien.

2





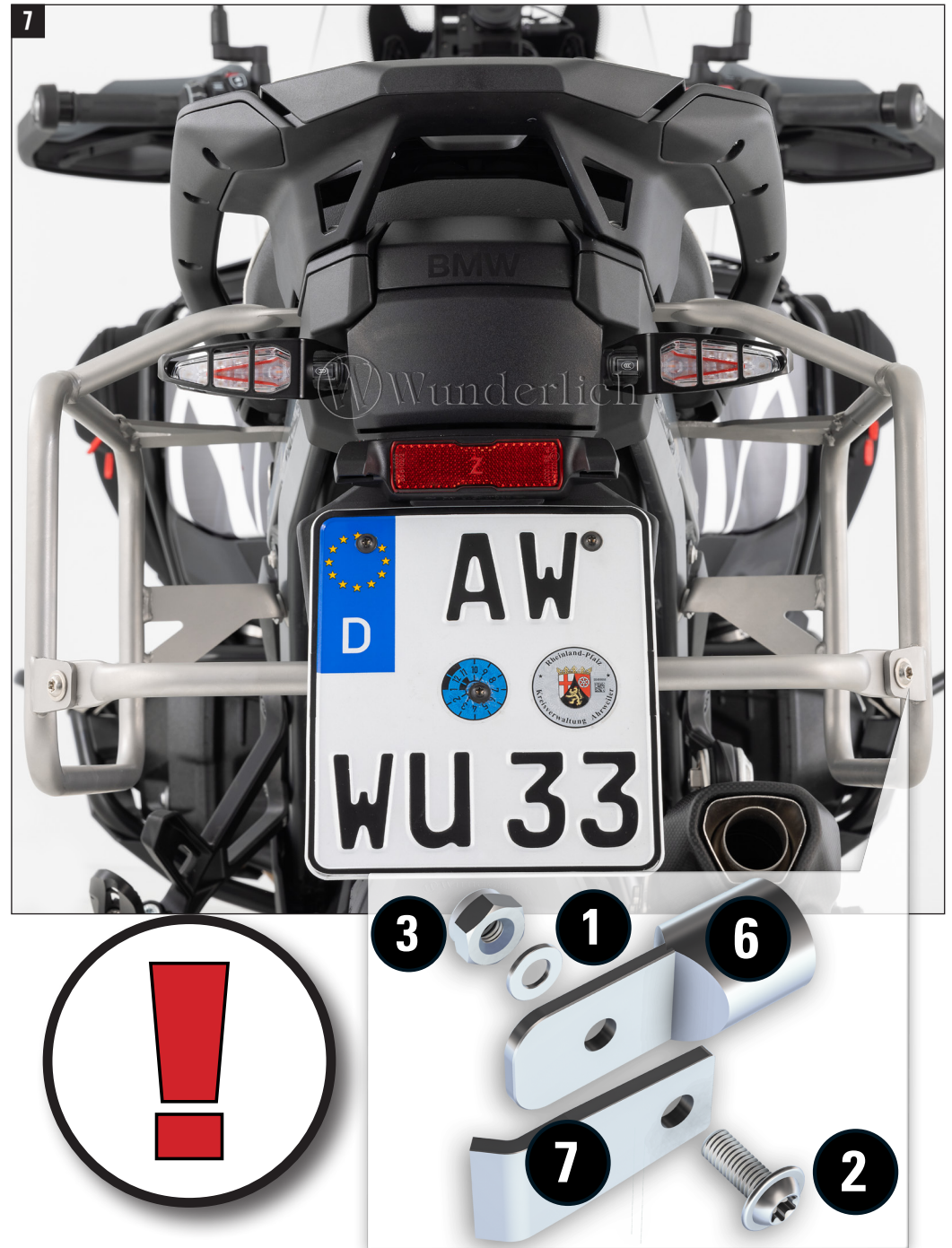
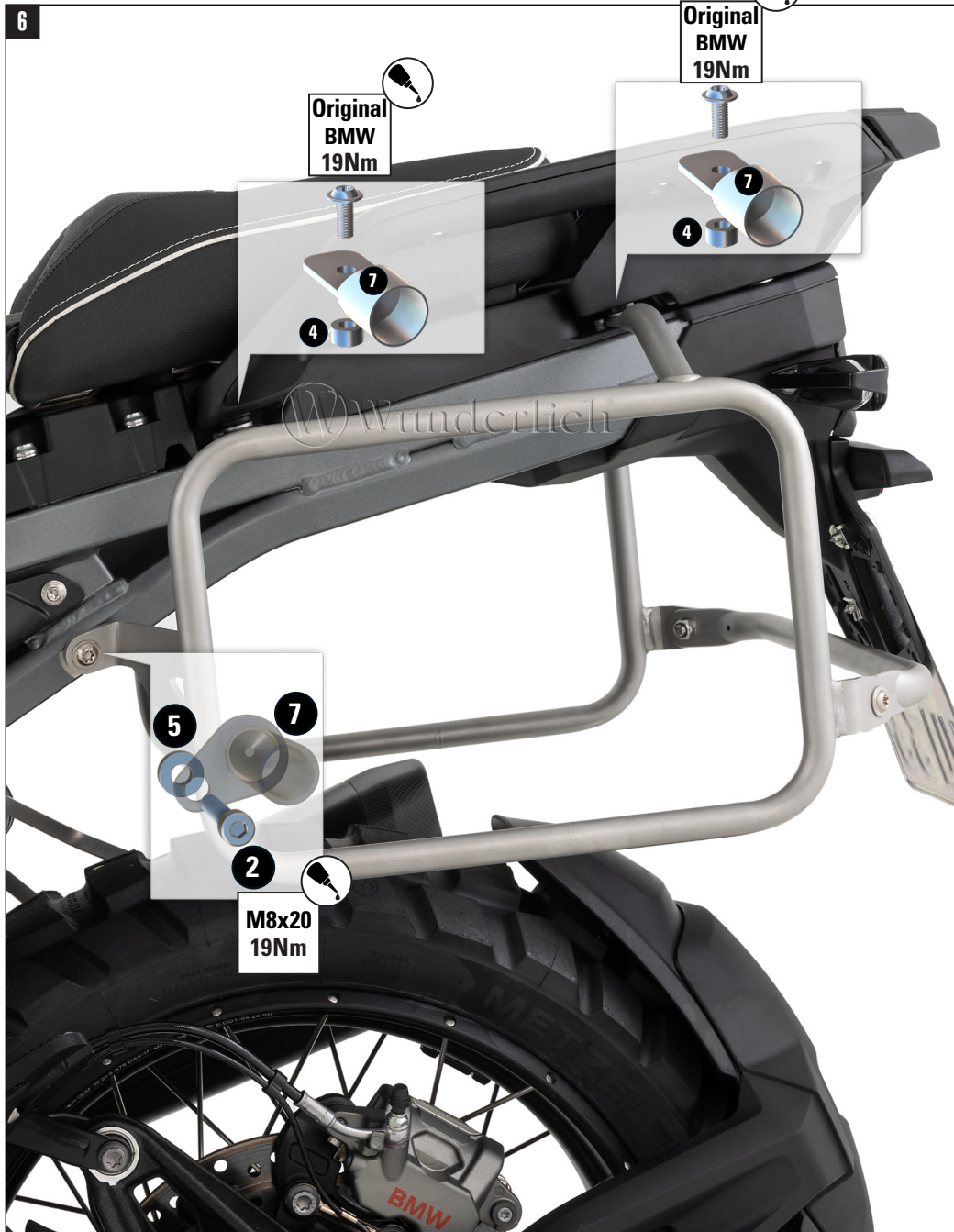

8

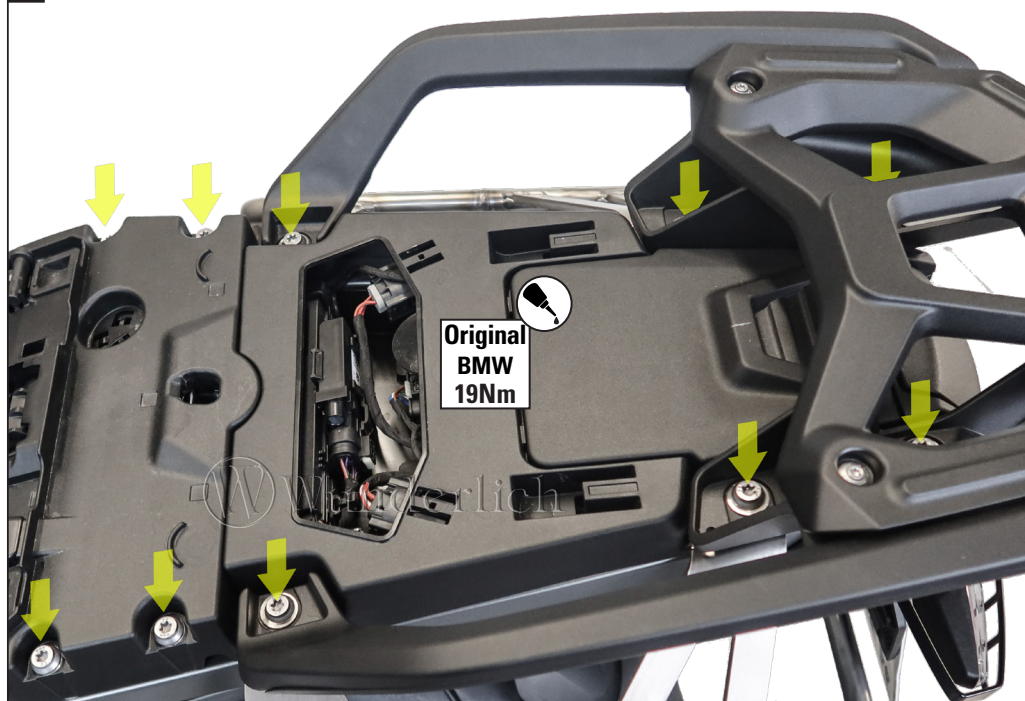

9



Verriegelung des Koffers und die Verschraubung des Trägers, vor Fahrtantritt prüfen. Verschlüsse der Deckel müssen verriegelt sein. Empfohlenes Tempolimit mit Zuladung 180 km/h. Ungleichmäßiges oder unsachgemäßes Beladen kann das Fahrverhalten negativ beeinflussen.

Check before each journey that case/top case is securely attached to the carrier on the vehicle. Locks must be closed.

Recommended speed limit with load: 180 km/h (111 mph). Uneven or improper loading can affect the driving behaviour in a negative way.

Avant chaque voyage, vérifiez que la valise/le top case est bien fixé(e) au porte-bagages du véhicule. Les serrures doivent être fermées.

Limite de vitesse recommandée avec charge : 180 km/h (111 mph). Un chargement irrégulier ou incorrect peut avoir des conséquences négatives sur le comportement de conduite.

5

